

产品描述：KLNE1-S 系列

Product Description: KLNE01-S Series

目录

Index

1. 更改履历 Change History
2. 范围 Scope
3. 产品命名规则及描述 Product Naming Rules and Description
4. 相关标准 Related Standards
5. 参数范围 Parameter Ratings
6. 产品性能 Performance
7. 产品标识及包装规范 Identification and packaging

1. 更改履历 Change History

序号 No.	版本号 Version No.	更改前描述 Description Modification Before	更改后描述 Description modification After	更改人/日期 Reviser/Date
1	V1	NAME/UL/IEC		Nirw/25.3.4
2				
3				
4				
5				

2. 适用范围 Scope

本产品规格书适用于卡丽智能科技（嘉兴）有限公司生产的 PCB 连接器，产品系列名称：KLNE1-S 系列。

This product specification covers the requirement for PCB connector, which are designed and manufactured by KALI intelligent technology (Jiaxing) Co.,LTD. P/N: KLNE1-S.

3. 产品命名规则及描述 Product Naming Rules and Description

KLNE 系列产品为 PCB 连接器，产品命名规则及部件描述如下：

The KLNE series connector designed for PCB connector. Naming rules and part description as following form:

产品命名规则 Products Naming Rules

示例 Example:	KLNE1-P-5.00-V-1-GY	系列名称 KLN	应用 E	编号 1	类别 P	间距 5.00	方向 V	极数 1	颜色 GY
系列名称 Series name:	KLN								
应用 Application:	R=轨装式接线端子 Rail-Mount Terminal Blocks C=建筑布线用端子 Installation Terminal Blocks and Connectors E=PCB接线端子 PCB Terminal Blocks								
编号 No.:	1								
类别 Sort:	P=插拔式插头 Plug RP=插拔式反向插头 Reverse Plug S=插拔式插座 Socket F=固定式插座 Fixed Socket PL=插头带锁扣 Plug with Lock A=配件 Accessory								
间距 Pitch:	5.00=5.00 间距 Pitch								
方向 Direction:	H=0度卧式 0°Horizontal V=90度立式 90°Vertical W=180度卧式 180°Horizontal U=通用式 Unicersal L=左侧 Left M=中间 Mid R=右侧 Right								
极数 Pin:	1=1 Pin								
颜色 Color:	BK=黑色 Black GY=灰色 Gray OL=本色 Original RD=红色 Red WH=白色 White TT=透明 Transparent YE=黄色 Yellow BU=蓝色 Blue OG=橙黄 Orange GN=绿色 Green OT=其他 Other								

塑料件命名规则
Plastic Parts Naming Rules

示例	系列名称	应用	编号	类别	间距	方向	部件	材料编号	颜色	防火等级
Example: KLNE1-P-5.00-V_HO-1-GY-V0	KLN	E	1	P	5.00	V	HO	1	GY	V0
系列名称 Series name:	KLN									
应用 Application:	R=轨装式接线端子 Rail-Mount Terminal Blocks C=建筑布线用端子 Installation Terminal Blocks and Connectors E=PCB接线端子 PCB Terminal Blocks									
编号 No.:	1									
类别 Sort:	P=插拔式插头 Plug RP=插拔式反向插头 Reverse Plug S=插拔式插座 Socket F=固定式插座 Fixed Socket PL=插头带锁扣 Plug with Lock A=配件 Accessory									
间距 Pitch:	5.00=5.00 间距 Pitch									
方向 Direction:	H=0度卧式 0°Horizontal V=90度立式 180°Vertical W=180度卧式 180°Horizontal U=通用式 Unicursal L=左侧 Left M=中间 Mid R=右侧 Right									
部件 Parts:	HO=外壳 Housing CO=盖子 Cover LE=操作杆 Lever LR=锁扣杆 Lock Rod FL=法兰 Flange CL=卡扣 Clip									
材料编号 Material No.:	1=PA66 2=PA66+GR 3=PBT 4=PBT+GR 5=PC 6=POM									
颜色 Color:	BK=黑色 Black GY=灰色 Gray OL=本色 Original RD=红色 Red WH=白色 White TT=透明 Transparent YE=黄色 Yellow BU=蓝色 Blue OG=橙黄 Orange GN=绿色 Green OT=其他 Other									
防火等级 Flammability:	HB=UL94HB V0=UL94V-0 V1=UL94V-1 V2=UL94V-2									

金属件命名规则 Metal Parts Naming Rules

示例	系列名称	类别	编号	材质	处理工艺	送料方式	
Example:	KLN-SP-1-S-13-P	KLN	SP	1	S	13	P
系列名称 Series name:	KLN						
类别 Sort:	SP=弹簧 Spring CM=接触件 Contact Material NU=螺母 Nut SC=螺丝 Screw GA=垫片 Gasket						
编号 No.:	1						
材质 Material:	B=黄铜 Brass P=磷铜 Phosphor Bronze S=不锈钢 Stainless Steel N=洋白铜 Nickel Silver Alloy R=紫铜 Red Copper C=镁铜 Copper Magnesium Alloy L=铝 Aluminium A=铍铜 Beryllium Bronze F=铁 Ferrum						
处理工艺 Processing:	01=无 None 02=镀镍 Nickel Plating 03=镀镍银 Silver-Nickel Plating 04=镀镍金 Gold-Nickel Plating 05=镀镍局部金 Half Gold-Nickel Plating 06=镀亮锡局部金 Half Gold-Tin Plating 07=镀雾锡 Matte Tin Plating 08=镀亮锡 Bright Tin Plating 09=镀镍雾锡 Matte Tin-Nickel Plating 10=镀铅锡 Tin-Lead Plating 11=镀铜锡 Tin-Cu Grinding 12=化学研磨 Chemical Grinding 13=热处理 Heat Treatment						
送料方式 Feeding Way:	P=散件 Parts T=料带 Tape						

塑料件

Plastic parts

名称 Name	部件型号 Part Model	备注 Notes
插座左壳 Left female plug housing	KLNE1-S-5.00-L_H0-1- GY-V0	PA66 UL94V0
插座中壳 Middle female plug housing	KLNE1-S-5.00-M_H0-1- GY-V0	PA66 UL94V0
插座右壳 Right female plug housing	KLNE1-S-5.00-R_H0-1- GY-V0	PA66 UL94V0

金属件

Metal parts

直针 Straight pin header	KLN-CM-3-R-07-P	T2 - Matte Tin Plating (4-8um)
弯针 Curved pin header	KLN-CM-2-R-07-P	T2 - Matte Tin Plating (4-8um)

4. 相关标准 Related Standards

以下参考文件是本规格书的一个组成部份。若本规格书中的要求与产品图纸发生冲突，则产品图中的要求为优先；若本规格书中的要求与参考文件中的要求冲突，则本规格书为优先。

The following documents form a part of this specification. In the event of conflict between the requirements of this specification and the product drawing, the product drawing shall take precedence. In the event of conflict between the requirements of this specification and the referenced documents, this specification shall take precedence.

《UL 标准：UL1059》

《IEC 标准：IEC 61984》

5. 参数范围 Parameter Ratings:

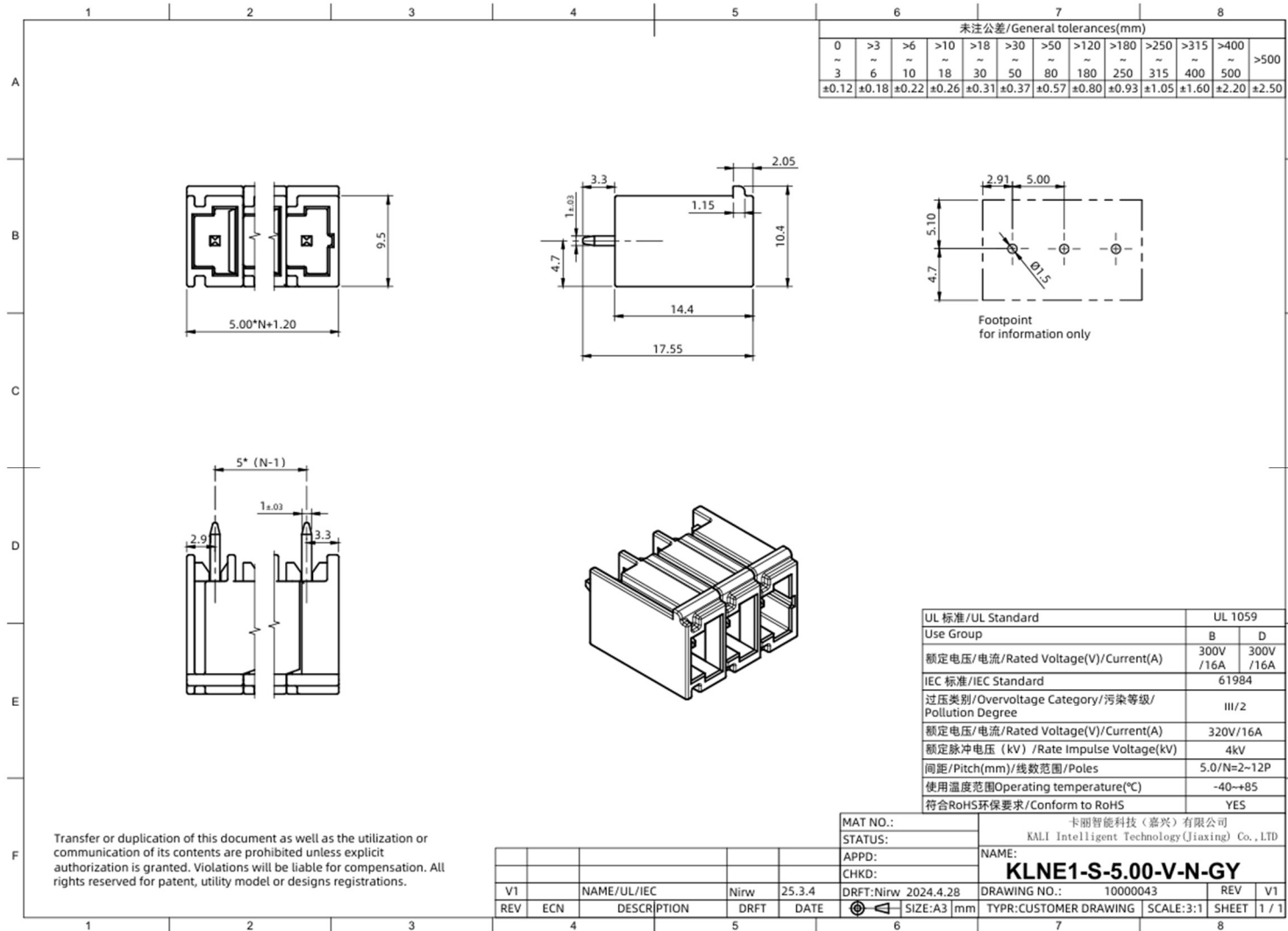

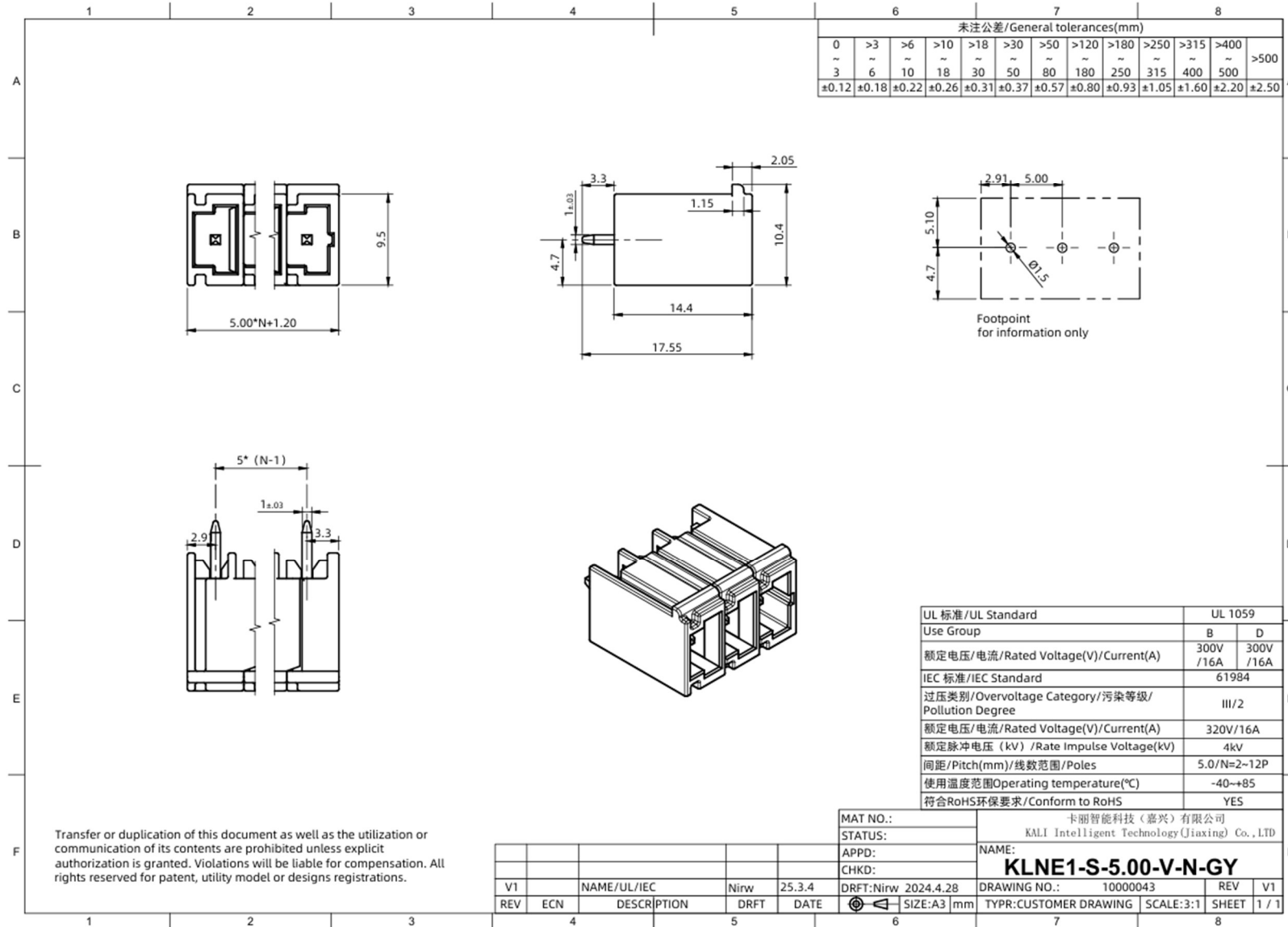

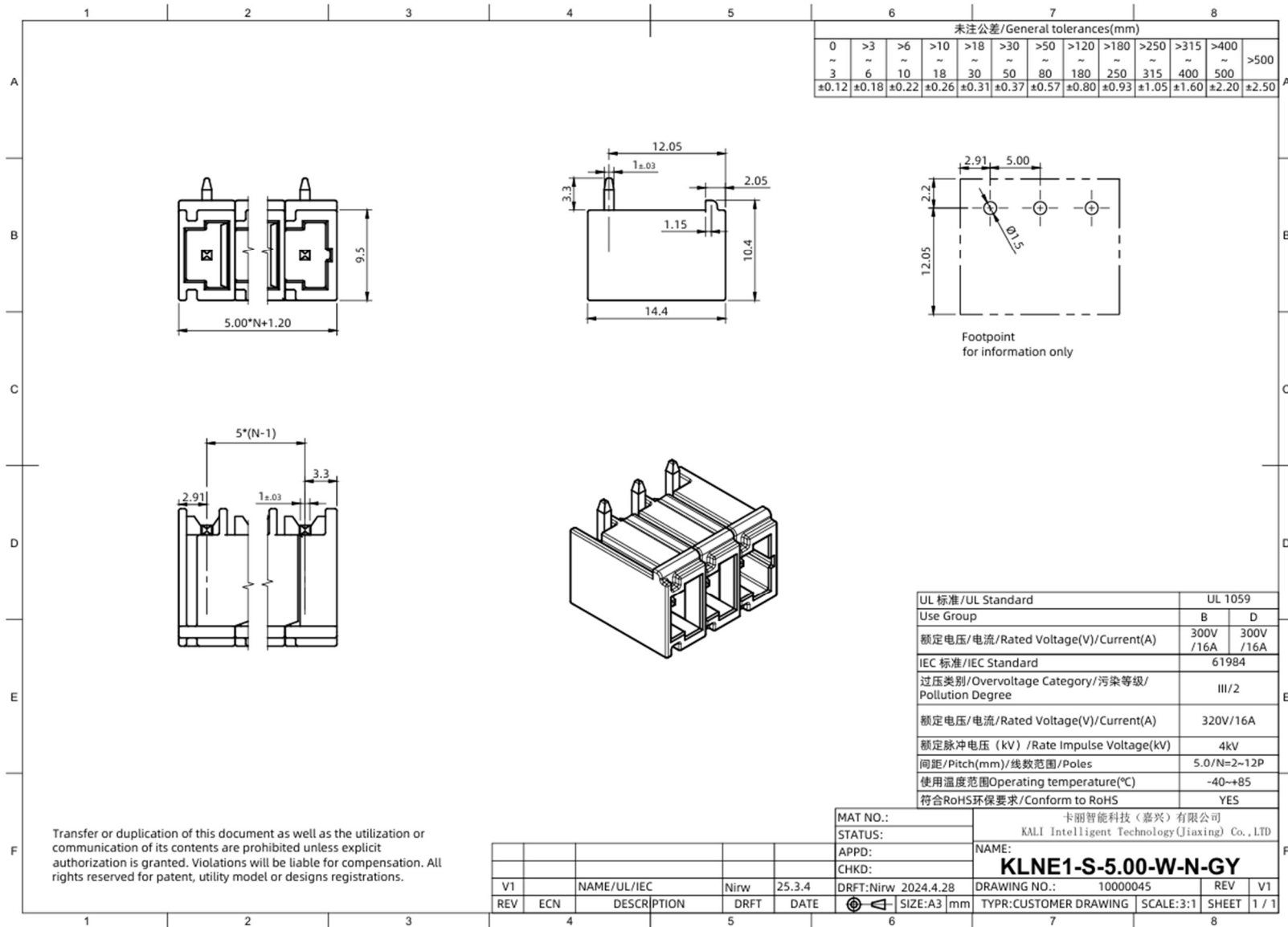

KLNE 插座参数 KLNE PCB Socket headers parameter ratings		
UL 标准 UL Standard	UL1059	
Use Group	B	D
额定电压 / 电流 Rated Voltage(V) / Current(A)	300V/16A	300V/16A
IEC 标准 IEC Standard	IEC 61984	
过压类别 / 污染等级 Overvoltage Category / Pollution Degree	/2	
额定电压 / 电流 Rated Voltage(V) / Current(A)	320V/16A	
额定脉冲电压(kV) Rate Impulse Voltage(kV)	4kV	
间距 / 线数范围 Pitch(mm) / Poles	5.00/N=2~12P	
使用温度范围 Operating Temperature(°C)	-40~+85°C	
符合 RoHS 环保要求 Conform to RoHS	YES	

6. 产品性能测试 Performance test

序号 No.	项目 Item	测试条件 Test Condition	规格 Requirement
6.1.1	外观 Appearance	目测 Visual inspection 视力: 1.0 以上 Visual acuity: 1.0 or above 照明: (200~300) lx Lighting: (200-300) lx 目测距离: (0.3~0.5) m Visual inspection distance: (0.3-0.5) m	1. 塑料件表面应无明显疤痕、凹陷、开裂及影响使用的变形。 The surface of the plastic parts should be free from obvious scars, dents, cracks, and deformations that affect usability. 2. 金属件表面无锈蚀、氧化、无明显的机械损伤及电镀层脱落等缺陷。 The surface of the metal parts should be free from rust, oxidation, obvious mechanical damage, and defects such as peeling of the plating layer.
6.1.2	壳体/ 端子固 定力 Housing/ Terminal retention force	固定连接器或测力计, 在连接器轴线方向 世家规定的拉力; 速度不大于 25mm/min。 Apply axial pull out force at the speed rate of not more 25mm/min on the pin assembled in the housing.	8N
6.1.3	摆锤冲 击试验 Pendulum impact test	冲击元件质量为 150g±1g。 The weight of the striking element is 150g ± 1g. 跌落高度 25cm, 对连接器所有部位进行冲 击试验。 The drop height is 25cm. All parts of the connector shall be subjected to the impact test.	不应出现任何导致带电部件不能 继续保持在位或不能确保有效防 触电的破碎、开裂或变形。 There should be no fractures, cracks, or deformations that would prevent the live parts from remaining in place or from ensuring effective protection against electric shock.

6.2 电气性能测试 Electrical test

序号 No.	项目 Item	测试条件 Test Condition	规格 Requirement
6.2.1	防潮试验 Moisture resistance test	样品在温度为 20°C~30°C，相对湿度为 (93±2)% 的潮湿箱放置 48h。Place the samples in a humidity chamber with a temperature of 20°C to 30°C and a relative humidity of (93±2)% for 48 hours.	产品不应出现结构性的损坏。 The tested samples must not exhibit any structural damage.
6.2.2	绝缘电阻 Insulation resistance	先后连接 20AWG 的导线和 12AWG 的导线，并施加约 500V 的直流电压进行测试。 Connect the 20AWG wire and the 12AWG wire in turn, and perform the test by applying a DC voltage of about 500V.	绝缘电阻不得小于 5MΩ The insulation resistance must not be less than 5 MΩ.
6.2.3	绝缘电压 Insulation voltage	额定绝缘电压 250V， 试验电压 2000V，频率 50Hz，1min。 Testing parameters: Rated insulation voltage: 250V; testing voltage: 2000V; frequency: 50 Hz; duration: 1 minute. 试验期间，不得出现闪络或击穿。 a.所有连接在一起的夹紧件与无固定装置的连接器件 的本体或所有连接在一起的夹紧件与有固定装置的连接器件的安装底座上的夹紧件之间； During the test, there should be no occurrence of flashover or breakdown between the clamping parts of all connected components without fixing devices, such as the body of connectors, and between the clamping parts on the mounting base of connectors with fixing devices.	无击穿、闪络和飞弧现象 No breakdown, flashover, or arcing should be observed during the test.
6.2.4	温升 Temperature rise	额定电流(Rated current): 16A; 线径(wire diameter): 2.5mm ² 试验力矩(Testing torque): ——N·m	1h 或热稳定后，温升 ≤45K Temperature rise shall be ≤45K after 1h or after thermal stability is achieved.
6.3.1	耐高温 High temperature resistance	灼热丝试验： Glow wire test: 保持载流部件和接地电路部件在位的绝缘材料部件 For the insulation material components responsible for keeping the current-carrying parts and grounding circuit parts in place, perform the Glow Wire Test. 试验温度：850°C	移去灼热丝后 30s 内，样品上的火焰或灼热熄灭。 绢纸不应起火，松木板不应烧焦。 After removing the glow wire, the flame or

		Testing temperature: 850°C	glowing on the sample should extinguish within 30 seconds. The silk paper should not catch fire, and the pine wood board should not be charred.
6.3.2	绝缘材料的耐电痕化 Electrical tracking resistance of insulation materials	PTI 175V, 使用溶液 A, 液滴滴落时间间隔为 30s ± 5s。 Conditions for conducting the electrical tracking resistance test: PTI (Proof Tracking Index): 175V Solution: A Droplet application interval: 30s ± 5s	过流继电器应不动作或试样未燃烧。 The overcurrent relay should not activate, or the sample should not ignite.
6.3.5	盐雾 Salt spray test	把试验样品从试验箱顶悬挂下来, 采用浓度为 (5±1)%(质量百分比)的氯化钠溶液, 在(35±2)°C温度下连续雾化 48h, 试验后用流动的蒸馏水轻轻洗去表面沉积物。在常温常湿条件下恢复 1~2h。 Suspend the test sample by hanging it from the top of the test chamber. Apply a sodium chloride (NaCl) solution with a concentration of (5 ± 1)% (by mass percentage). Maintain continuous spray for 48 hours at a temperature of (35 ± 2)°C. After the test, gently rinse off the surface deposits using flowing distilled water. Allow 1-2 hours of recovery of the sample under normal temperature and humidity conditions.	外观: 无损伤(五金件应无露出底金属的严重锈蚀;使用预镀好的型材, 其落料面允许有不影响其性能的轻微腐蚀。) Appearance: No damage should be observed (Metal parts should not have severe exposed metal corrosion; pre-plated profiles may have slight corrosion on cut surfaces that does not affect their performance).

7. 产品标识及包装规范 Identification and packaging

 KALI 卡丽	产品标识及包装规范 Identification and Packaging		交付客户 Delivery to customer	
			客户编码 Customer Code	
			包装图号 Package Drawing No.	
			版本 Version	V1.0
系列 SERIES	KLNE 系列接线端子 KLNE series wiring terminals	型号 MODEL	KLNE	
产品标识 Identification	产品标识 & 打标位置 Identification and marking position	印刷工艺 Printing technique	激光打标 Laser marking	
		备注 Remarks: 紫外激光器 Ultraviolet laser emitter		

	独立包装袋 Individual packaging bag	产品包装材质 Packaging material		产品包装尺寸 (长*宽/mm) Packaging dimensions (L*W/mm)	
		标签尺寸 mm Label dimensions (mm)	无 N/A	数量/包 pcs/box	
		标签材质 pcs/box	无 N/A	中文字体 Chinese font	无 N/A

内包装盒 & 包装规范 Inner box/ Packaging specs	内包装标签 Inner packing label	内包装材质 Inner packing material		内包装尺寸 (长*宽*高/mm) Packaging dimensions (L*W/mm)		
		标签尺寸 mm Label dimensions		数量/盒 pcs/pack		
		标签材质 Label material		中文字体 Chinese font		英文字体 English font
内包装盒 & 标签位置 Inner box/label position	内包装盒 & 标签位置 Inner box/label position					

外箱 & 包装规范 Outer carton/packaging specs	外箱 & 标签 Outer carton label	包装箱 Packing carton	外箱材质 Outer carton material	■BC 五层板 (中性包装无印刷) ■BC five-layer board (neutral packaging without printings)				
			外尺 (长*宽*高/mm) Outer dimensions (L*W*H/mm)		装箱数量 Packing quantity			
		标签材质 Label material	<input checked="" type="checkbox"/> 机打标签 (不干胶) <input type="checkbox"/> 印刷标签 <input checked="" type="checkbox"/> Computer-printed labels (self-adhesive sticker) <input type="checkbox"/> Printed labels			标签尺寸 mm dimensions		
		其它 Others	包装打包带 Packing tape	<input type="checkbox"/> 井字 Cross-pattern strapping tapes <input type="checkbox"/> Parallel tapes <input checked="" type="checkbox"/> 无需求 No special requirements				
			封口胶带 Sealing tape	■透明无字 Transparent, without words				
		标签印刷工艺 Label printing techniques	印刷标签 Printing labels	中文字体 Chinese font	黑体 Black	英文字体 English font	黑体 Black	
外箱 & 外箱标签位置 Outer carton/ Carton label position								

技术负责人 Technical head		审核 Reviewed by		批准 Approved by	
客户(简称)确认 Customer (in short name) confirmation			内部签审 Internal signed review		
确认者 Confirmed by			批准 Approved by	年 月 日 YYYY MM DD	
部门 Dept.			销售代表 Sales representative	年 月 日 YYYY MM DD	
日期 Date	年 月 日 YYYY MM DD	制定 Prepared by		年 月 日 YYYY MM DD	
<p>特别注明： 整份文件提交客户确认，客户在末页签字确认。若客户未会签可由销售代表代签，但必须提供相关佐证资料（如包装交付客户检验的合格记录等）。</p> <p>Special notes: The entire document is to be submitted for customer confirmation, and the customer may choose to sign and confirm on the last page. In case the customer is unable to give the signature, the sales representative may sign on their behalf, but relevant supporting documents (such as records of qualified inspection upon delivery to the customer) must be provided as evidence.</p>					