

1 2 3 4 5 6 7 8

未注公差/General tolerances(mm)												
0	>3	>6	>10	>18	>30	>50	>120	>180	>250	>315	>400	>500
~	~	~	~	~	~	~	~	~	~	~	~	~
±0.12	±0.18	±0.22	±0.26	±0.31	±0.37	±0.57	±0.80	±0.93	±1.05	±1.60	±2.20	±2.50

A

A

B

B

C

C

D

D

E

E

F

F

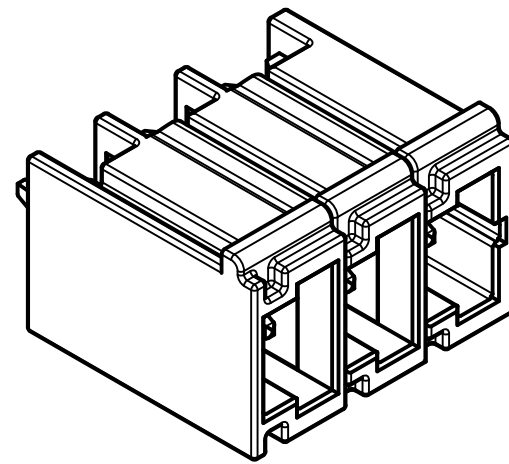
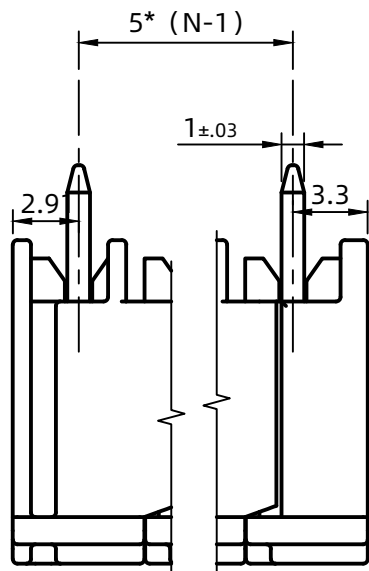
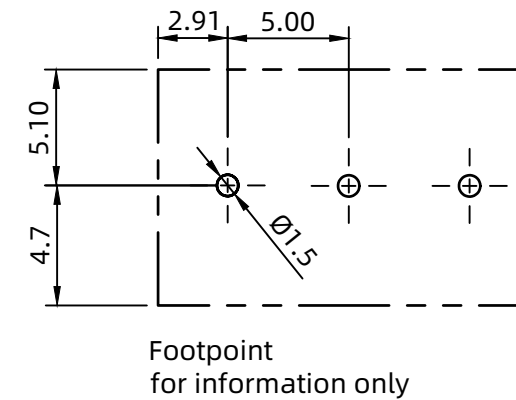
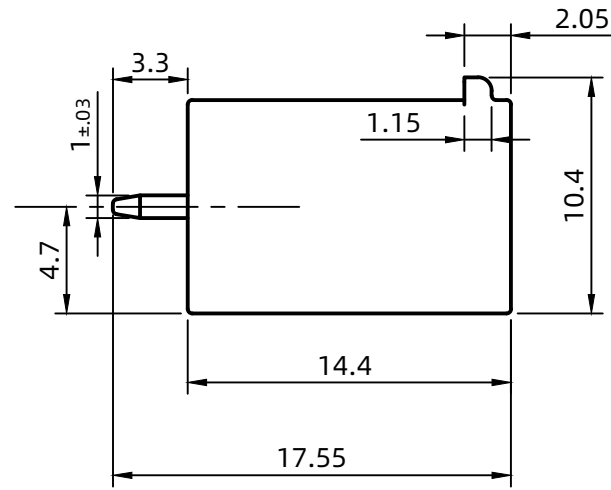
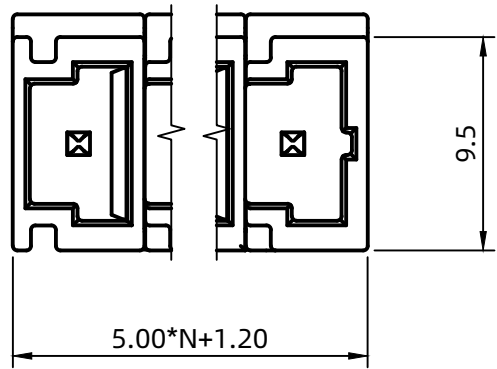

UL 标准/UL Standard	UL 1059	
Use Group	B	D
额定电压/电流/Rated Voltage(V)/Current(A)	300V /16A	300V /16A
IEC 标准/IEC Standard	61984	
过压类别/Overvoltage Category/污染等级/Pollution Degree	III/2	
额定电压/电流/Rated Voltage(V)/Current(A)	320V/16A	
额定脉冲电压 (kV) /Rate Impulse Voltage(kV)	4kV	
间距/Pitch(mm)/线数范围/Poles	5.0/N=2~12P	
使用温度范围Operating temperature(°C)	-40~+85	
符合RoHS环保要求/Conform to RoHS	YES	

Transfer or duplication of this document as well as the utilization or communication of its contents are prohibited unless explicit authorization is granted. Violations will be liable for compensation. All rights reserved for patent, utility model or designs registrations.

MAT NO.:					卡丽智能科技(嘉兴)有限公司 KALI Intelligent Technology(Jiaxing) Co.,LTD				
STATUS:					NAME:				
APPD:					KLNE1-S-5.00-V-N-GY				
CHKD:					DRAWING NO.: 1000043				
V1		NAME/UL/IEC	Nirw	25.3.4	DRFT:Nirw	2024.4.28	REV	V1	
REV	ECN	DESCRIPTION	DRFT	DATE	SIZE:A3	mm	TYPR:CUSTOMER DRAWING	SCALE:3:1	SHEET 1 / 1

1 2 3 4 5 6 7 8